

SPECIFICATION SHEET



MODEL NAME : SMD TOP LED (RR) 5050 2-C

PART NAME : 5050RR

ISSUED : 20. 11. 06

3DZ			CUSTOMER			
Prepared by	Checked by	Approved by				
ML	JB					

Remarks:

■ SMD LED : 5050RR

1. Feature

- High Luminous Intensity : Long operational life
- Low Current Application : Low power consumption
- Indoor / Outdoor Application
- 100% Probing Test
- Excellent Uniformity on Wavelength, Intensity and Forward Current

2. Applications

- Automotive : Backlighting in dashboard and switch
- Lighting device : Indicator , lighting
- Medical

3. Outline Drawing and Dimension

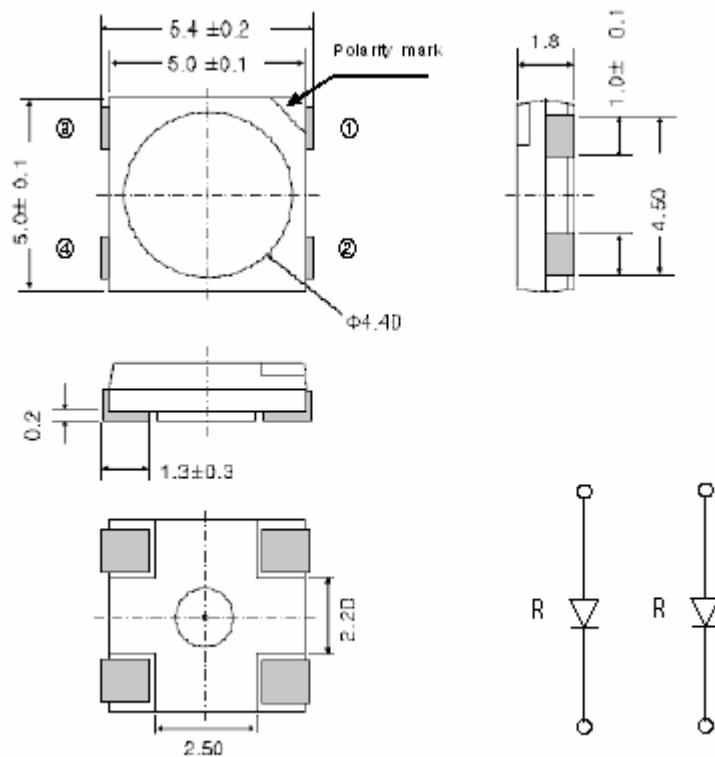

4. Absolute Maximum Ratings

Items	Symbols	Ratings	Unit
Operation Forward Current	I_F	50 / 50	mA
Peak Pulsed Forward Current(^{1/10} Duty)	I_{FP}	100	mA
Reverse Voltage	V_R	5	V
Power Dissipation*	P_D	182/ 120	mW
Operating Temperature Range	T_{OP}	-25~ 80	°C
Storage Temperature Range	T_S	-45 ~ 100	°C
Soldering Temperature	T_{SOL}	240±5°C	°C

* : Total value should be within the absolute maximum rating when illuminating more then two devices. max package rating 100 mA

5. Electrical & Optical Characteristics (Ta : 25 °C)

Parameter	Symbol	Conditions	Min.	Typ.	Max.	Unit.	
Forward Voltage	VF	$I_F = 70mA$	Red		2.2	2.6	V
		$I_F = 20mA$	Red		2.2	2.6	V
Reverse Current	IR	$V_R = 5V$	R/G	-	-	50	uA
Dominant Wavelength	WD	$I_F = 20mA$	Red	630	635	640	nm
		$I_F = 20mA$	Red	630	635	640	nm
Luminous Intensity	IV	$I_F = 20mA$	Red	-	1500	250	mcd
			Red	-	1500	250	mcd

* Luminous intensity is reading value of LX4560A LED Tester

* Luminous intensity is measured with a photo detector and filter combination that follows

the CIE etc – response curve. And the equipment measured luminous intensity tolerance is ±5%

RED

6-1. Typical Characteristic Curve

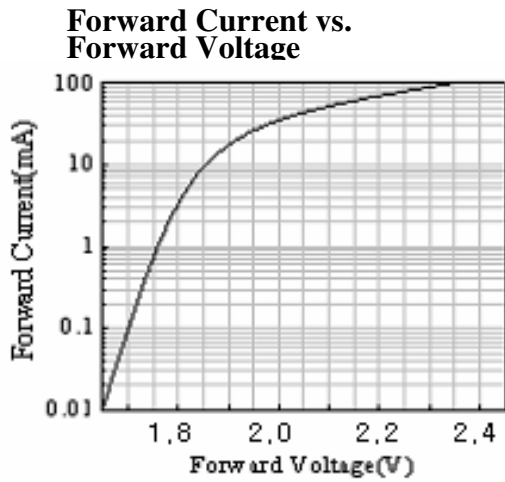

Forward Current vs. Ambient Temperature

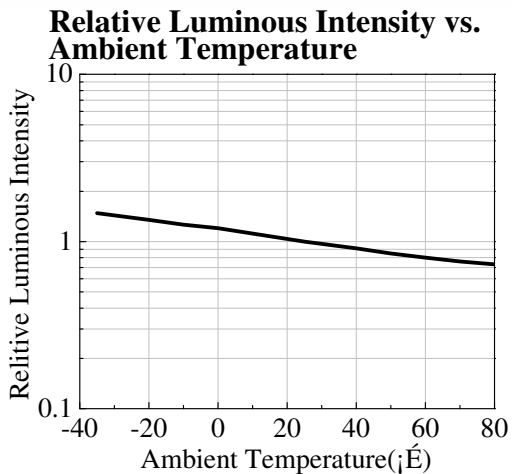
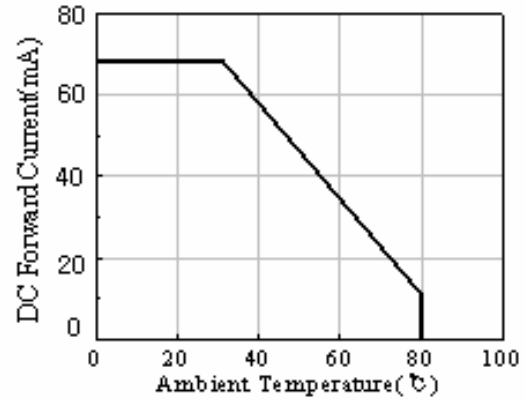

Luminous Intensity vs. Forward Current

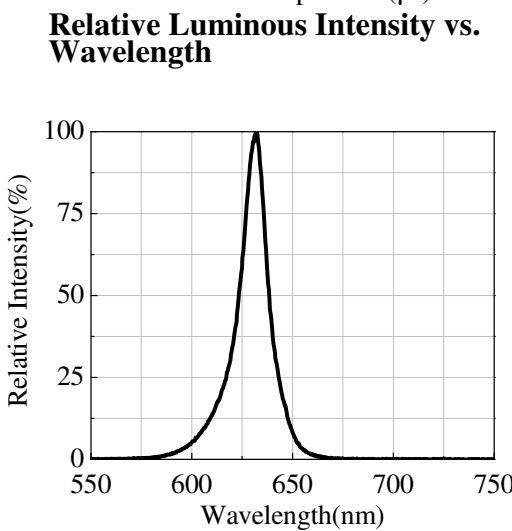
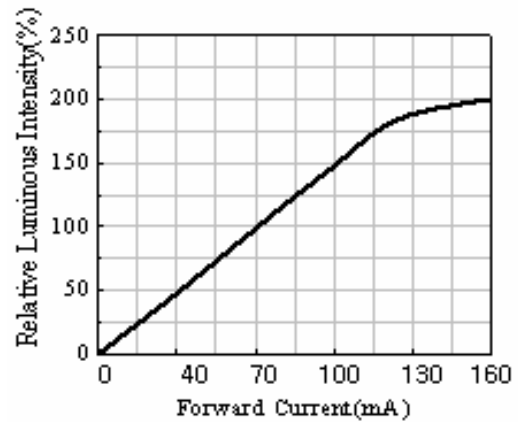

Radiation Diagram

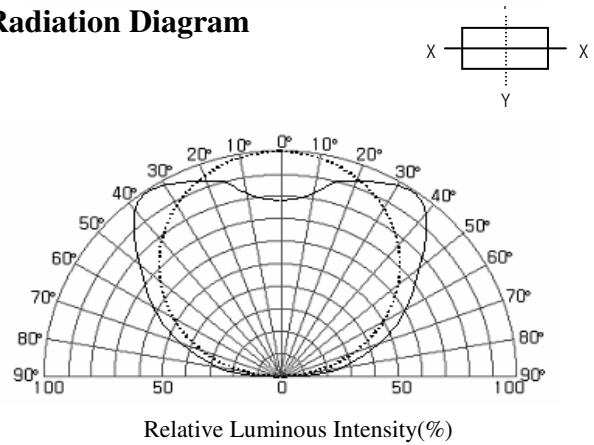

7. Solder Conditions

7.1 Reflow Conditions

Preliminary heating to be at 180°C max. for 120 Seconds max.

Soldering heat to be at 260°C max. for 5sec. Max.

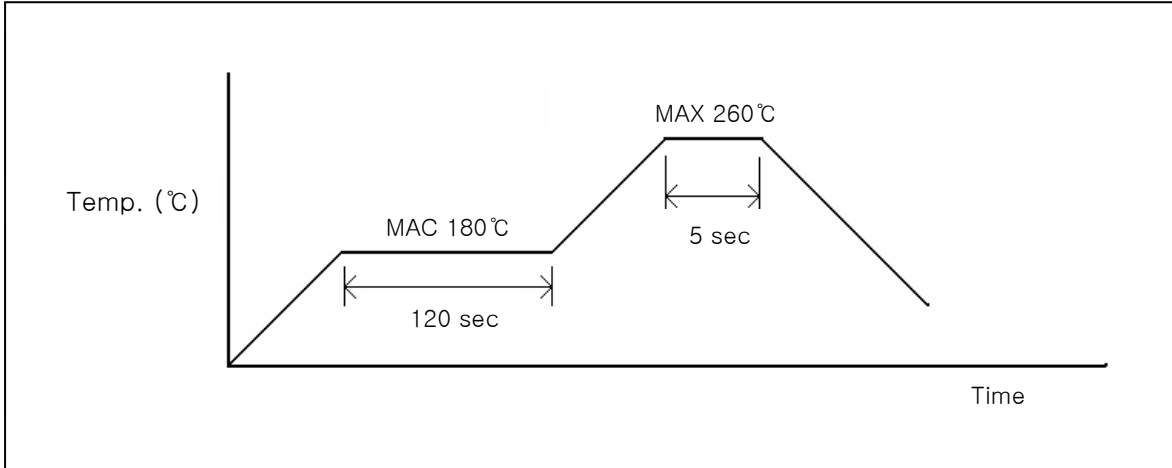

7.2 For manual Soldering

Not more than 3sec @MAX300°C, under soldering iron

7.3 Recommendable soldering pattern (For reflow solder)

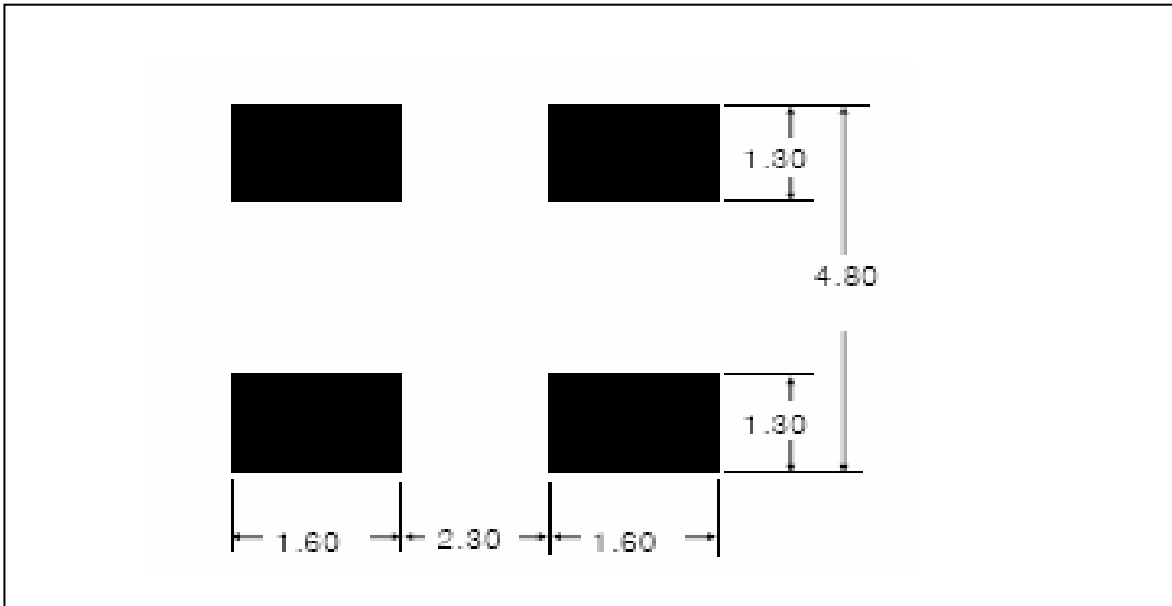

8. Dimension of Tape / Reel

(Unit : mm)

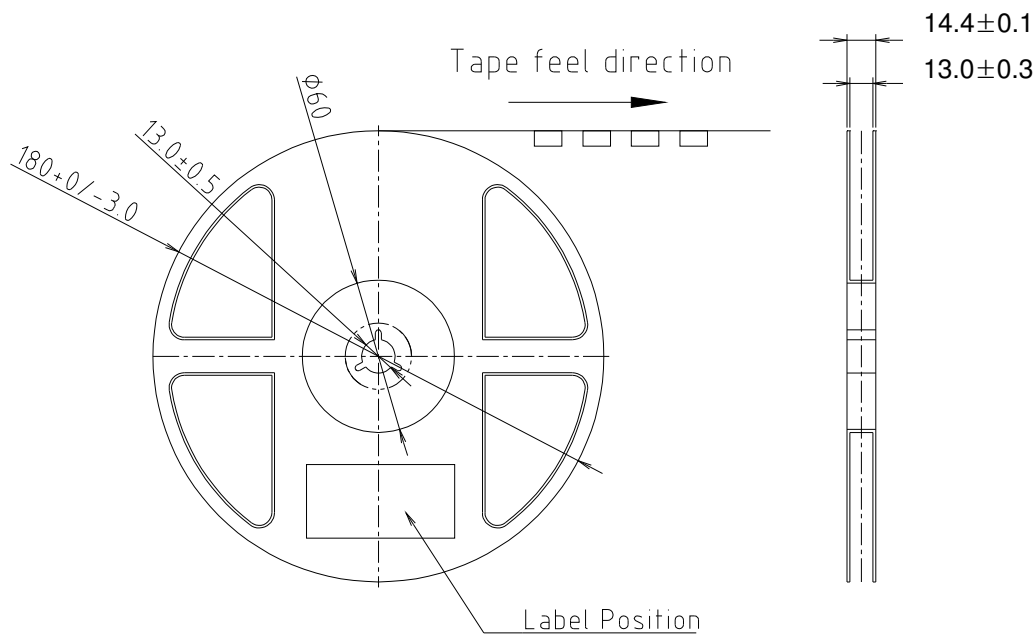
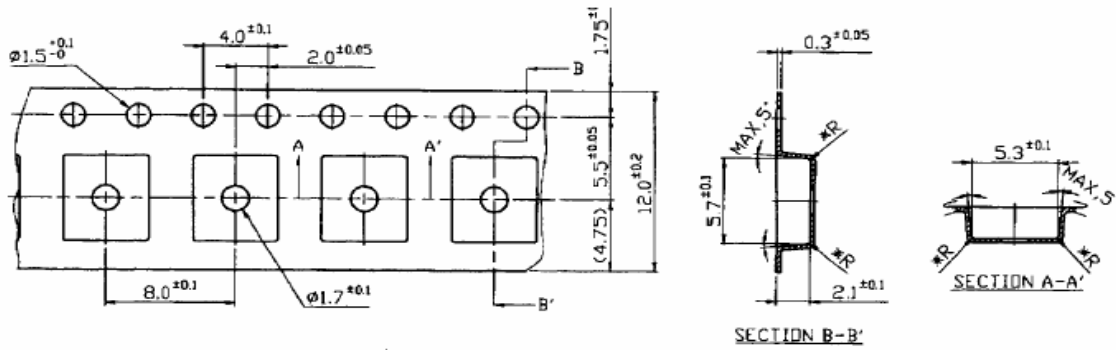

- (1) Quantity : Product are packed in one taping reel of max. **2,000** pcs.
- (2) Cumulative Tolerance : Cumulative Tolerance/10 pitches to be ± 0.2 mm
- (3) Adhesion Strength of Cover Tape : Adhesion strength to be 0.1-0.7N when the cover tape is turned off from the carrier tape at 10°C angle to be the carrier tape.
- (4) Packaging : P/N, Manufacturing data Code No. and quantity to be indicated on a damp proof Package.

9. Packing Structure

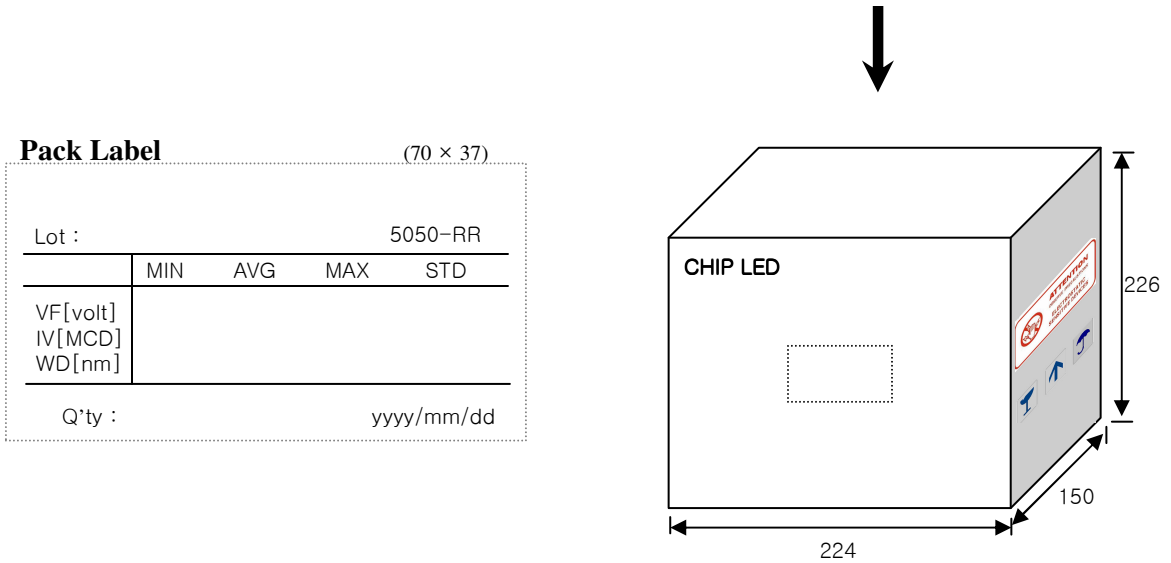
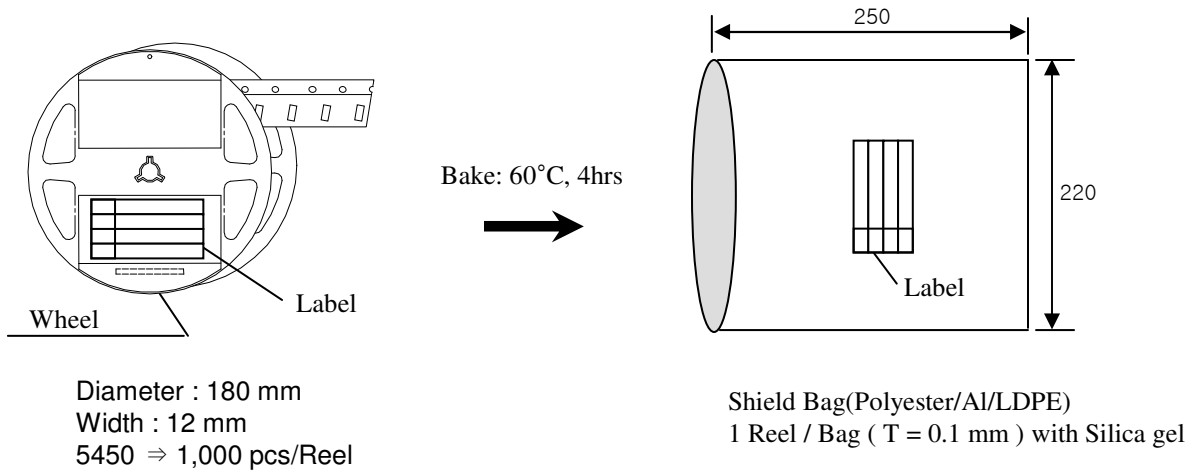

Maximum 10 Bags / 1 Inner Box
505 ⇒ 10,000 pcs/ 1 Inner Box

10. Precaution for use

- This device should not be used in any type of fluid such as water, oil, organic solvent, etc.
When washing is required, IPA should be used.
- When the LEDs are illuminating, operating current should be decided after considering the ambient maximum temperature.
- LEDs must be stored to maintain a clean atmosphere.
If the LEDs are stored for 3 months or more after being shipped from 3DZ, a sealed container with a nitrogen atmosphere should be used for storage.
- After opening the package, the LED's should be kept at 30 °C, 70%RH or less.
The LEDs must be dip soldered within seven days(168 hours) after opening the moisture-proof packing.
- Repack unused Products with anti-moisture packing, fold to close any opening and then store in a dry place.
- The appearance and specifications of the product may be modified for improvement without notice.
- This LEDs is sensitive to the electrostatic and surge,
It is recommended to use a wrist band or anti-electrostatic glove when handling the LEDs.

If over-voltage which exceeds the absolute maximum rating is applied to LEDs, It will cause damage LEDs and result in destruction.

Damaged LEDs will show unusual characteristics such as leak current remarkably increase, turn-on voltage becomes lower and the LEDs get unlight at low current.

- It is better not to use different rank LEDs.
If use mixed rank, could not attain your object for highest quality of products.

11. Reliability

11.1 Reliability Test Item

Test Items	Test Conditions	Notes
High Temperature Storage	100 °C , 500 hr.	0/32
Low Temperature Storage	-45 °C , 500 hr.	0/32
Temp. Humidity Storage	50 °C , 95 % RH, 500 hr.	0/32
Steady State Operating life	25 °C , 20 mA , 500 hr.	0/32
High Temperature Operating Life	80 °C , 20 mA, 500 hr.	0/32
Low Temperature Operating Life	-25 °C , 20 mA, 500 hr.	0/32
Steady State Operating life Of High Humidity Heat	50 °C , 95 % RH, 20 mA 500 hr.	0/32
Temperature Cycle	-25 °C(30min) → 25(5min.) → 80(30min.) , 100 cycle	0/22
ESD	HBM, 100pF, 1.5kohm, 3 times	0/22
Pressure Cooker Test	121 °C , 2 atm., 99.6 % RH 48 hr.	0/22

11.2 Criteria for Judging the Damage

Items	Test Conditions	Criteria for judgment
Luminous Intensity (IV)	IF=20 mA	> 50% of S
Forward Voltage (VF)	IF=20 mA	Less than 120% of U
Reverse Current (IR)	VR=5 V	Less than 10 μ A

* U means the upper limit of specified characteristics, S means initial value.

12. Part Name Description

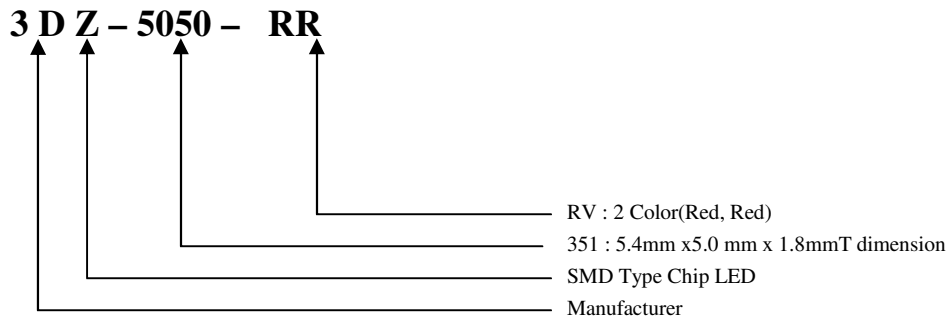

13. ATTENTION : Electric Static Discharge (ESD) Protection



The symbol shown on the page herein to introduce 'Electro-Optical Characteristics'. ESD protection for GaP and AlGaAs based chips is still Necessary even though they are safe in low static-electric discharge. Material in AlInGaP, GaP, or/and InGaN based chips are **STATIC SENSITIVE** devices. ESD protection has to be considered and taken in the initial design stage. If manual work/process is needed, please ensure the device is well protected from ESD during all the process. LED's ESD Level is 'Class 1' and The range of Forward Voltage is 1V ~ 1999V.

After opening the package, the LED's should be kept at 30°C, 70%RH or less.
The LEDs must be dip soldered within seven days(168 hours) after opening the moisture-proof packing.
It is better not to use different rank LEDs.
If use mixed rank, could not attain your object for highest quality of products.